

A



Surname _____

Other Names _____

Centre Number _____

Candidate Number _____

Candidate Signature _____

I declare this is my own work.

**GCSE
COMBINED SCIENCE: SYNERGY**

Higher Tier Paper 3 Physical Sciences

H

8465/3H

Monday 1 June 2020

Afternoon

Time allowed: 1 hour 45 minutes

At the top of the page, write your surname and other names, your centre number, your candidate number and add your signature.

[Turn over]



J U N 2 0 8 4 6 5 3 H 0 1

For this paper you must have:

- a ruler
- a protractor
- a scientific calculator
- the periodic table (enclosed)
- the Physics Equations Sheet (enclosed).

INSTRUCTIONS

- Use black ink or black ball-point pen. Pencil should only be used for drawing.
- Answer ALL questions in the spaces provided. Do not write on blank pages.
- If you need extra space for your answer(s), use the lined pages at the end of this book. Write the question number against your answer(s).
- Do all rough work in this book. Cross through any work you do not want to be marked.
- In all calculations, show clearly how you work out your answer.



INFORMATION

- **The maximum mark for this paper is 100.**
- **The marks for questions are shown in brackets.**
- **You are expected to use a calculator where appropriate.**
- **You are reminded of the need for good English and clear presentation in your answers.**

DO NOT TURN OVER UNTIL TOLD TO DO SO



01

A student investigated how the power output of a filament lamp varied with the current in the lamp.

FIGURE 1 shows part of the circuit the student used.

FIGURE 1

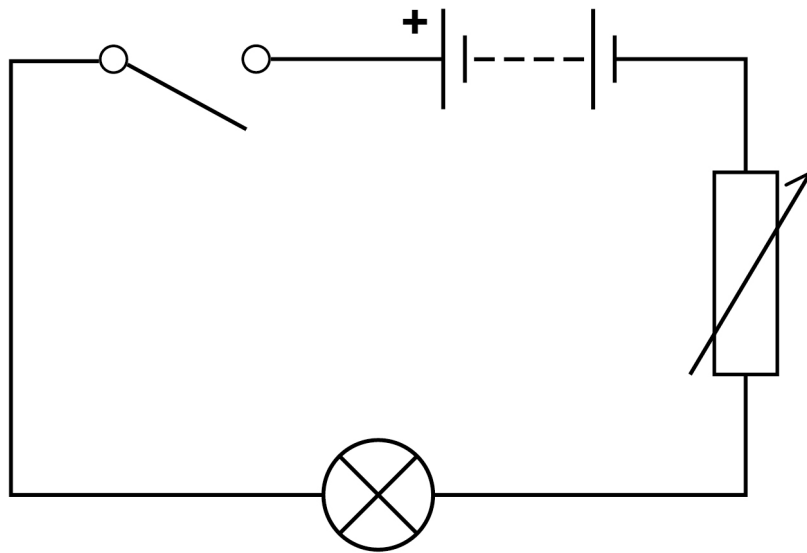

0 1 . 1 To calculate power output the student measured the current in the lamp and the potential difference across the lamp.

Complete **FIGURE 1** by adding an ammeter and a voltmeter to make the measurements.

Use the correct circuit symbols. [3 marks]

0 1 . 2 Which energy store in the battery decreases when the lamp is switched on? [1 mark]

0 1 . 3 What happens to the energy transferred by the lamp? [1 mark]

[Turn over]



FIGURE 2 shows the results.

FIGURE 2

Power
output
in watts

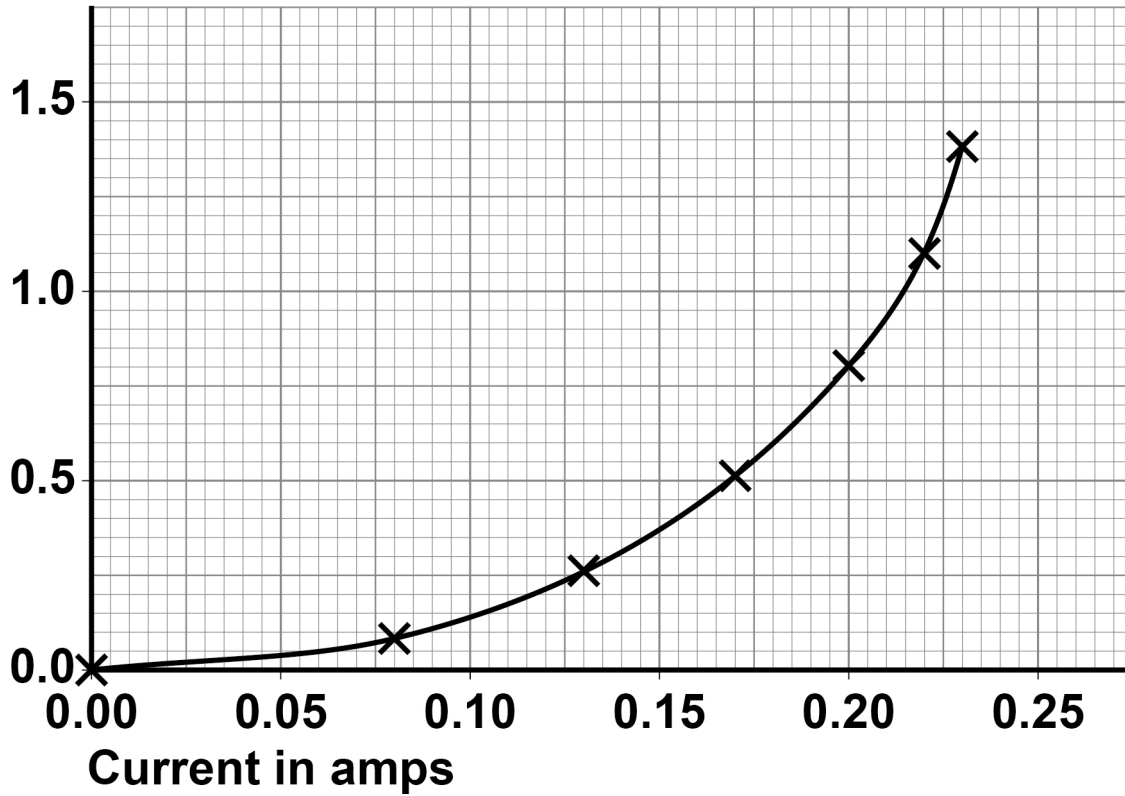

0 1 . 4 Describe how varying the current affects the power output of the filament lamp. [2 marks]

0 1 . 5 Write down the equation which links current (I), power (P) and resistance (R). [1 mark]

[Turn over]



BLANK PAGE

[Turn over]



02

A student investigated the temperature increase when magnesium powder was added to copper sulfate solution.

FIGURE 3 shows the apparatus used.

FIGURE 3

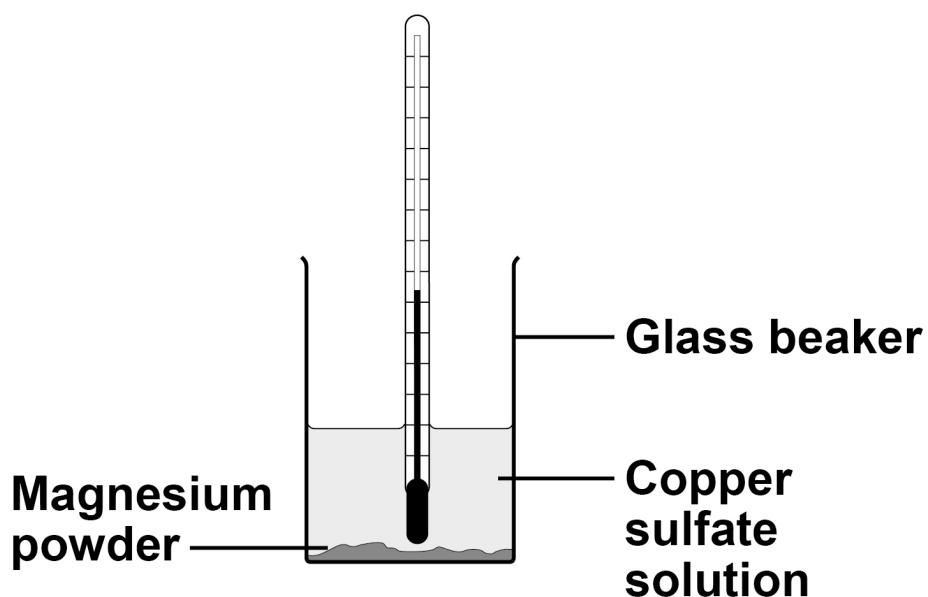

This is the method used.

1. Add copper sulfate solution to a beaker.
2. Measure the initial temperature of the copper sulfate solution.
3. Add 0.1 g of magnesium powder.
4. Stir the mixture.
5. Measure the maximum temperature of the mixture.
6. Repeat steps 1 to 5 with different masses of magnesium powder.



0 2 . 1 Give TWO control variables the student should use. [2 marks]

1 _____

2 _____

0 2 . 2 Suggest ONE change to improve the accuracy of the investigation. [1 mark]

[Turn over]



0 2 . 3 TABLE 1 shows the student's results.

TABLE 1

Mass of magnesium in g	Temperature increase in °C
0.1	3
0.2	6
0.3	9
0.4	12
0.5	15
0.6	18
0.7	21
0.8	21
0.9	24
1.0	21

Explain the conclusions that can be made from the trends shown in the results.

**Use data from TABLE 1 in your answer.
[6 marks]**



03

This question is about iron and steel.

FIGURE 4 shows a flow chart for the production of iron and steel from iron ore.

Iron ore consists mainly of iron oxide.

FIGURE 4



03

1 In the blast furnace iron oxide reacts with carbon monoxide to form iron and carbon dioxide.

Complete the equation for the reaction between iron oxide and carbon monoxide.

You should balance the equation. [2 marks]

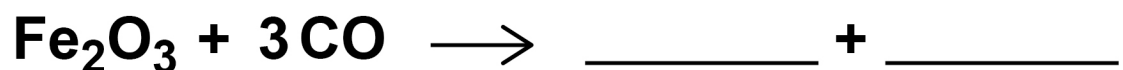

03.2 Iron oxide is reduced in the reaction with carbon monoxide.

**What does 'reduced' mean in this reaction?
[1 mark]**

[Turn over]



03.3 Cast iron is an alloy.

Cast iron contains carbon.

FIGURE 5 shows the arrangement of atoms in pure iron and in cast iron.

FIGURE 5

Pure iron

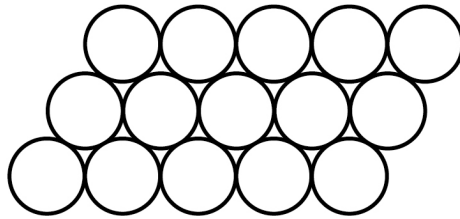

Cast iron

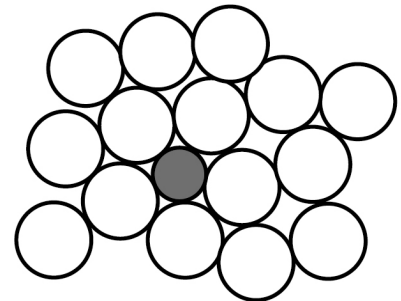

Explain why cast iron is harder than pure iron.
[4 marks]

[Turn over]



03.4 In addition to cast iron, scrap steel is added to the steel-making furnace.

Give THREE environmental advantages of recycling scrap steel in this way. [3 marks]

1 _____

2 _____

3 _____

10



0 4 This question is about the enzyme amylase.

0 4 . 1 Amylase can only digest starch.

Explain why amylase CANNOT digest other substances. [2 marks]

[Turn over]



Students investigated the effect of pH on the rate of starch digestion.

This is the method used.

- 1. Add 2 cm³ of amylase solution at pH 5.0 to a test tube in a water bath at 37 °C**
- 2. Add 2 cm³ of starch suspension to the same test tube.**
- 3. Start the timer.**
- 4. Remove a drop of the amylase-starch mixture after 30 seconds.**
- 5. Test the drop for starch.**
- 6. Repeat steps 4 to 5 until no starch is detected.**
- 7. Record the total time taken for no starch to be detected.**
- 8. Repeat steps 1 to 7 using amylase solution at different pHs.**



0 4 . 2 Which is the dependent variable in the investigation? [1 mark]

Tick (✓) ONE box.

pH of amylase solution

Temperature of water bath

Time for no starch to be detected

Volume of starch suspension

[Turn over]



0 4 . 3 Describe the test for starch.

**Give the result of the test if starch is present.
[2 marks]**

Test _____

Result _____

0 4 . 4 The amylase solution and starch suspension were kept in the water bath at 37 °C for 10 minutes before being mixed.

Why were the amylase and starch kept at 37 °C for 10 minutes before being mixed? [1 mark]



BLANK PAGE

[Turn over]



TABLE 2 shows the results.

TABLE 2

pH	Time for no starch to be detected in seconds
5.0	420
5.5	330
6.0	270
6.5	240
7.0	120
7.5	90
8.0	120
8.5	180
9.0	270



0 4 . 5 Student A concluded that:

‘The optimum pH for amylase is 7.5’.

Give ONE reason why this conclusion could be correct.

Use TABLE 2. [1 mark]

0 4 . 6 Student B concluded that:

‘The optimum pH is between 7.0 and 8.0 but may not be 7.5’.

How can student B determine a more accurate value for the optimum pH?

Use TABLE 2. [1 mark]

[Turn over]

8



0 5

This question is about the hydrocarbons obtained from crude oil.

Octane is a hydrocarbon.

The formula of octane is C_8H_{18}

0 5**1**

How does the formula of octane show that octane is an alkane? [1 mark]



The fractions in crude oil are separated by fractional distillation.

FIGURE 6 shows a fractionating column.

FIGURE 6

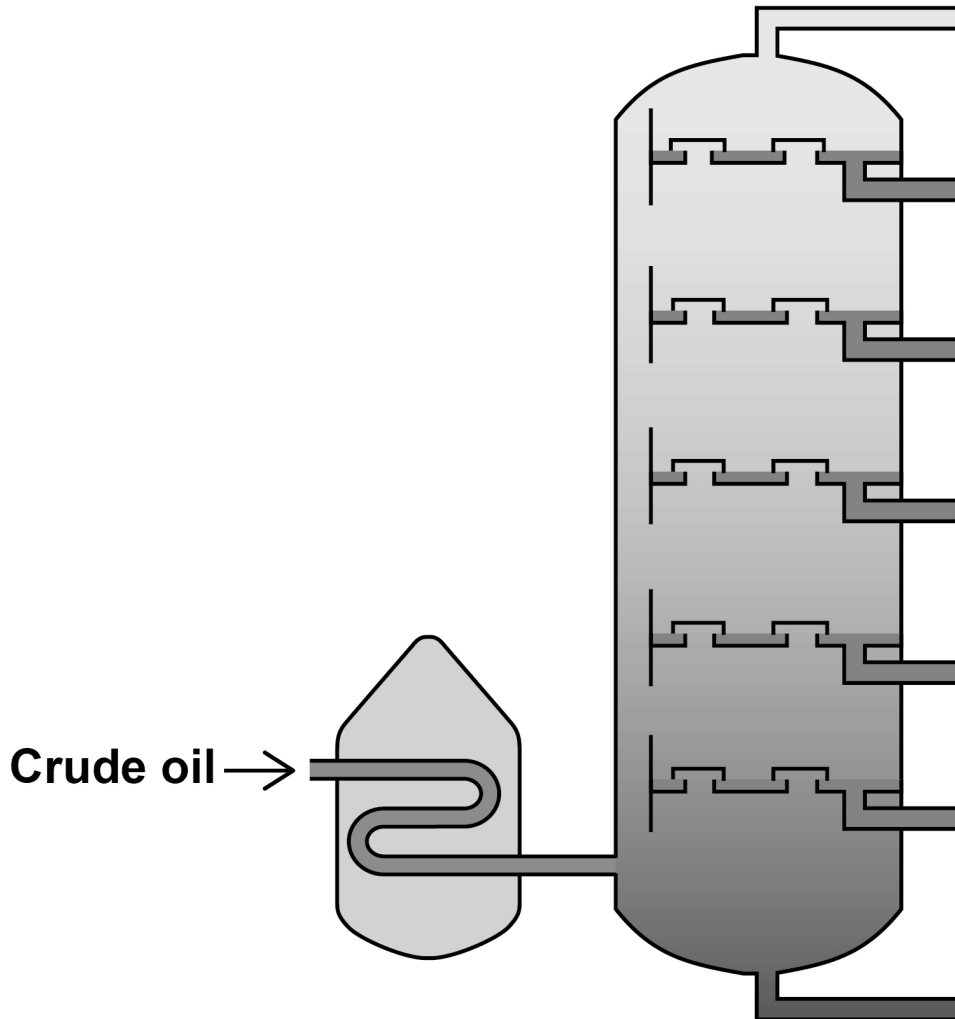

[Turn over]



TABLE 3 gives some properties of different fractions separated from crude oil.

TABLE 3

Fraction	Range of number of carbon atoms per molecule	Boiling point range in °C
Diesel	C₁₅–C₂₀	250–300
Heavy fuel oil	C₂₀–C₂₅	300–400
Kerosene	C₁₀–C₁₅	180–250
Petrol	C₅–C₁₀	40–180



0 5 . 2 Which fraction in TABLE 3 is the most viscous?

Give ONE reason for your answer. [2 marks]

Tick (✓) ONE box.

Diesel

Heavy fuel oil

Kerosene

Petrol

Reason _____

[Turn over]



BLANK PAGE



06

Some security lights automatically switch on when it gets dark.

FIGURE 7 shows a security light.

FIGURE 7

Light-dependent resistor (LDR)

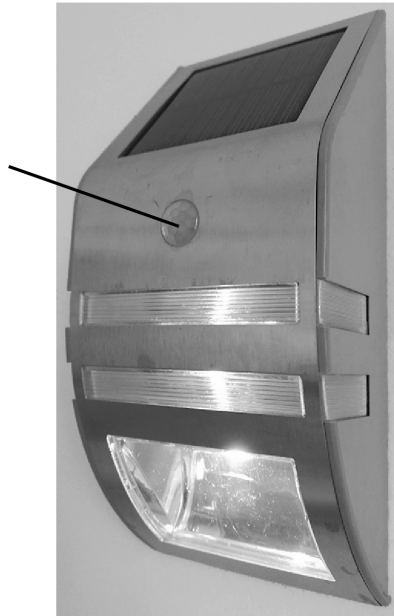
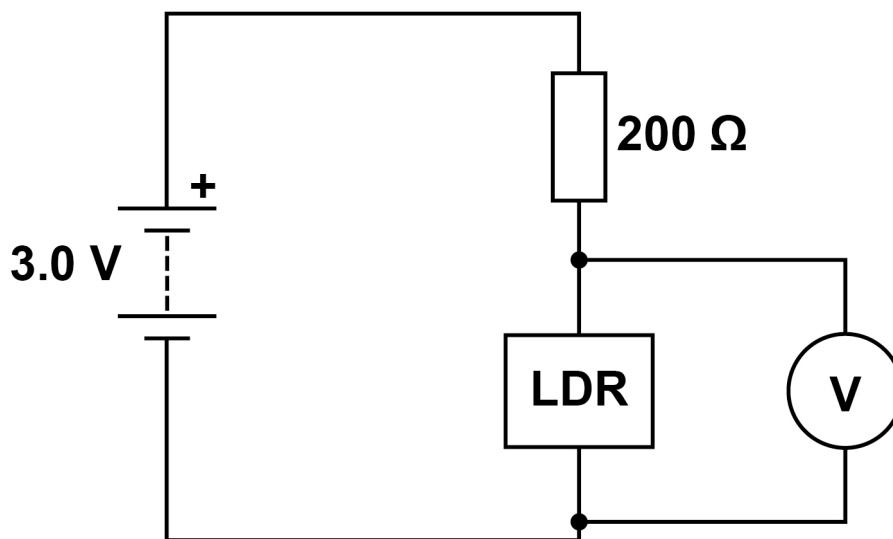

FIGURE 8 shows part of a circuit that can be used to switch the security light on and off.

FIGURE 8



06.1

The circuit symbol for the LDR in FIGURE 8 is NOT correct.

Which is the correct circuit symbol for the LDR? [1 mark]

Tick (✓) ONE box.

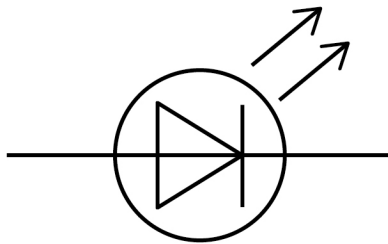

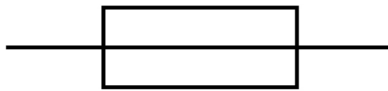

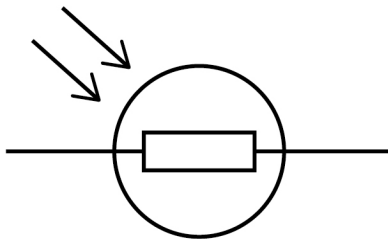

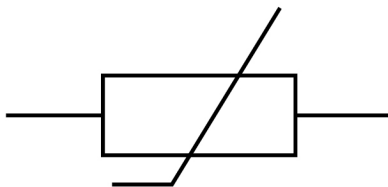

[Turn over]



REPEAT OF FIGURE 8

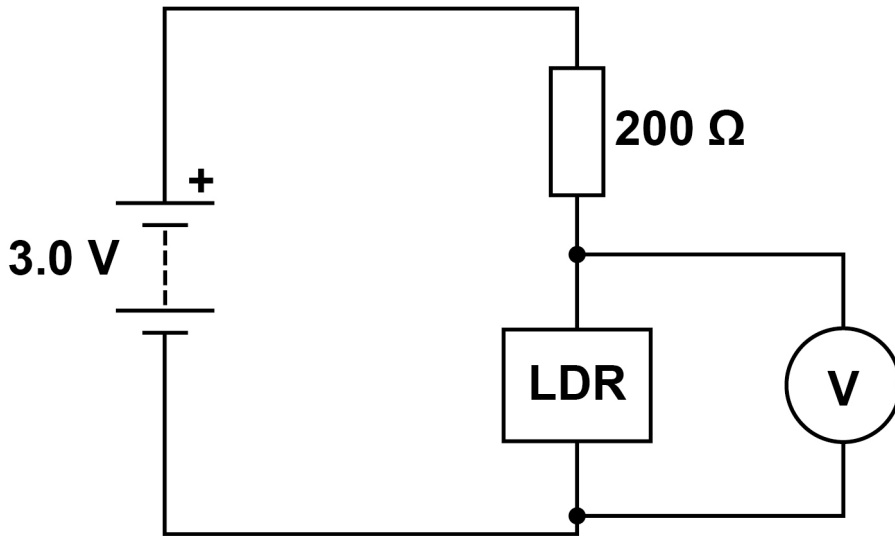

06.2 The security light turns on when the potential difference across the LDR is 2.0 V

Determine the resistance of the LDR when the potential difference across the LDR is 2.0 V

Use FIGURE 8. [2 marks]

Resistance = _____ Ω



06.4

Sometimes dirt can cover the LDR on the security light.

What effect would dirt on the LDR have on the security light? [1 mark]

Tick (✓) ONE box.

The security light would always be off.

The security light would always be on.

The security light would only be on during the day.

The security light would only be on during the night.

8



BLANK PAGE

[Turn over]



07

FIGURE 9 shows a car travelling at a constant speed on a straight, level road.

FIGURE 9

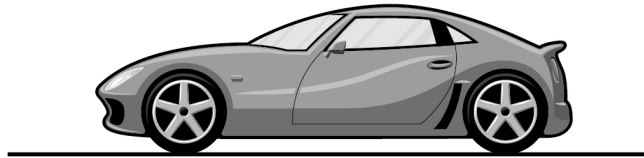
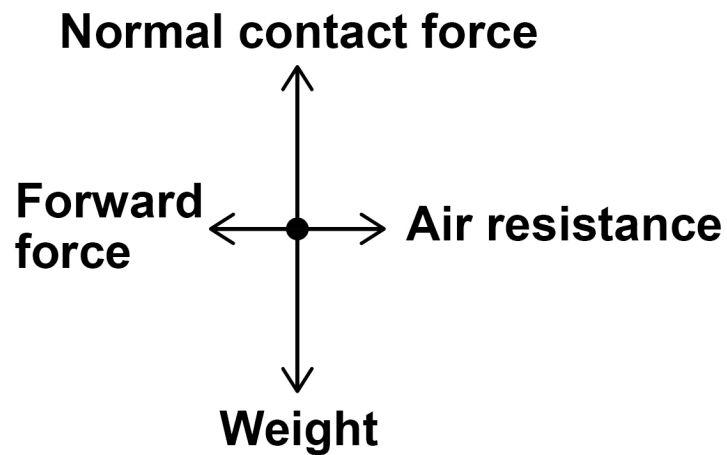

FIGURE 10 shows a free body diagram for the car.

FIGURE 10



- 07.1** Explain how the free body diagram shows that the resultant force on the car is zero.
[3 marks]

[Turn over]



TABLE 4 shows how the braking distance of a car varies with the speed of the car.

TABLE 4

Speed in metres per second	Braking distance in metres
6	3
12	12
18	27
24	48

07.2 A car decelerates from 24 m/s to 0 m/s

The work done by the brakes in decelerating the car is 210 000 J

Determine the mean braking force.

Use information from TABLE 4.

Give your answer to 2 significant figures.

[4 marks]



Mean braking force (2 significant figures) =

_____ N

[Turn over]



REPEAT OF TABLE 4

Speed in metres per second	Braking distance in metres
6	3
12	12
18	27
24	48

0 7 . 3 The braking distance is directly proportional to the kinetic energy of the car.

Explain how the data in TABLE 4 supports this relationship. [3 marks]

[Turn over]

10



0 8 This question is about halogens.

Bromine reacts with sodium to produce sodium bromide.

0 8 . 1 Describe the structure of and bonding in sodium bromide. [2 marks]

0 8 . 2 The equation for the reaction is:

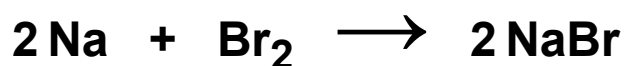

1 g of bromine reacts with sodium.

Calculate the number of bromine molecules in 1 g of bromine.



1 mole of bromine contains 6.02×10^{23}
bromine molecules.

Relative formula mass (M_r) of bromine = 160
[3 marks]

Number of bromine molecules =

[Turn over]



- 08.3** TABLE 5 shows the boiling points of some halogens.

TABLE 5

Halogen	Boiling point in °C
Bromine	60
Chlorine	-34
Fluorine	-188

Explain the trend in the boiling points of the halogens. [4 marks]

[Turn over]

9



BLANK PAGE



09

This question is about the industrial process used to produce ammonia.

Ammonia is produced from nitrogen and hydrogen.

09.1

Complete the dot and cross diagram for the ammonia molecule shown in FIGURE 11.

Show only the electrons in the outer shell of each atom. [2 marks]

FIGURE 11

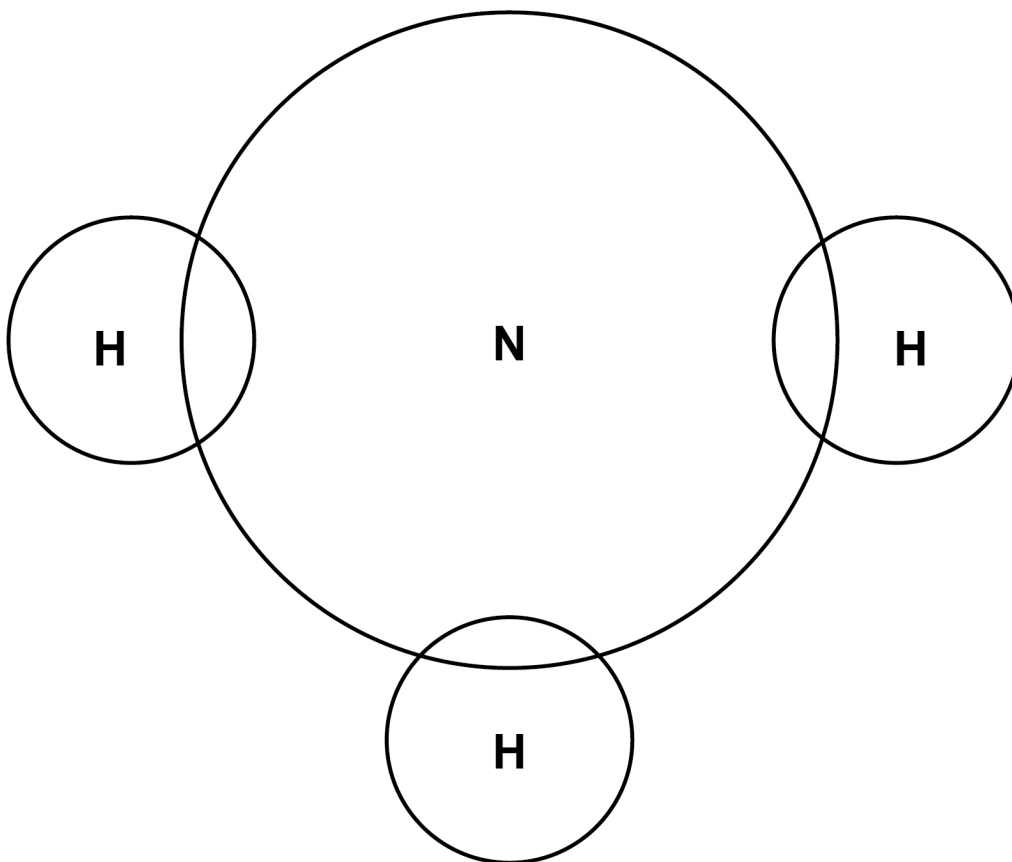

[Turn over]



Hydrogen is obtained from natural gas.

One stage in the process is to react carbon monoxide with steam.

The equation for the reaction is:

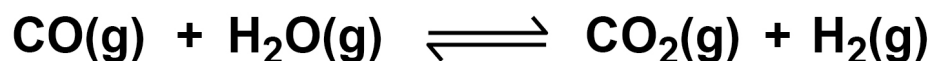

The forward reaction is exothermic.

In the industrial process, the reaction occurs at approximately 400 °C



09.2

The reaction between carbon monoxide and steam reaches dynamic equilibrium.

Which statement describes dynamic equilibrium? [1 mark]

Tick (✓) ONE box.

The forward reaction and the reverse reaction stop.

The forward reaction happens at the same rate as the reverse reaction.

The rate of the forward reaction is faster than the rate of the reverse reaction.

The rate of the forward reaction is slower than the rate of the reverse reaction.

[Turn over]



- 09.3** The reaction between carbon monoxide and steam is faster at 600 °C than at 400 °C

Explain why a temperature of 600 °C is NOT used in the industrial process. [2 marks]

- 09.4** Predict the effect of increasing the pressure on the yield of hydrogen.

Give ONE reason for your answer. [2 marks]

Prediction _____



Reason _____

0 9 . 5 Give TWO reasons why a catalyst is used in the reaction between carbon monoxide and steam. [2 marks]

1 _____

2 _____

[Turn over]



09.6 The carbon dioxide produced in this reaction can be used in fizzy drinks.

In fizzy drinks carbon dioxide gas dissolves in water to form an aqueous solution of carbonic acid.

Carbonic acid is a weak acid.

Explain the difference between a weak acid and a strong acid. [2 marks]



- 09.7** The equation for the production of ammonia from nitrogen and hydrogen is:

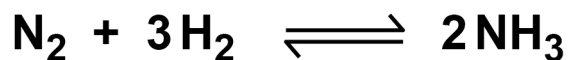

1.275×10^{11} kg of ammonia is used each year to manufacture fertilisers.

This is 85% of the ammonia produced each year.

Calculate the mass of nitrogen needed to manufacture the total mass of ammonia produced each year.

Relative atomic masses (A_r): $\text{H} = 1$ $\text{N} = 14$
[6 marks]

[Turn over]



BLANK PAGE

[Turn over]



FIGURE 12 shows the equipment a student used to investigate the motor effect.

FIGURE 12

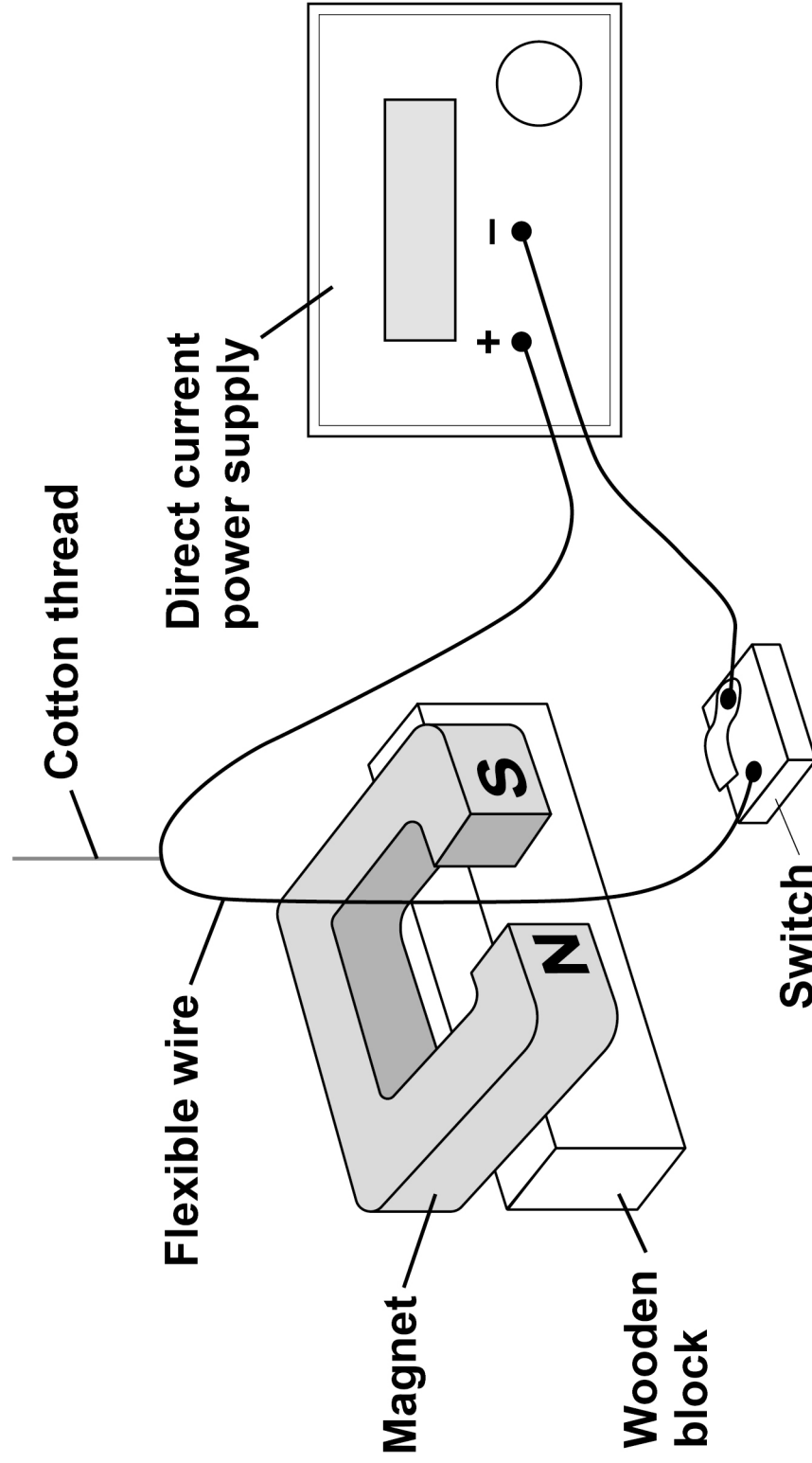

10.1 Explain why the wire moves when the switch is closed. [4 marks]

[Turn over]

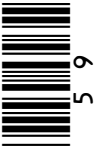

Magnetic flux density = _____

Unit _____

END OF QUESTIONS

10



BLANK PAGE

For Examiner's Use	
Question	Mark
1	
2	
3	
4	
5	
6	
7	
8	
9	
10	
TOTAL	

Copyright information

For confidentiality purposes, all acknowledgements of third-party copyright material are published in a separate booklet. This booklet is published after each live examination series and is available for free download from www.aqa.org.uk.

Permission to reproduce all copyright material has been applied for. In some cases, efforts to contact copyright-holders may have been unsuccessful and AQA will be happy to rectify any omissions of acknowledgements. If you have any queries please contact the Copyright Team.

Copyright © 2020 AQA and its licensors. All rights reserved.

IB/M/CH/Jun20/8465/3H/E3

